

## Optimal protection for heads with HiPIMS

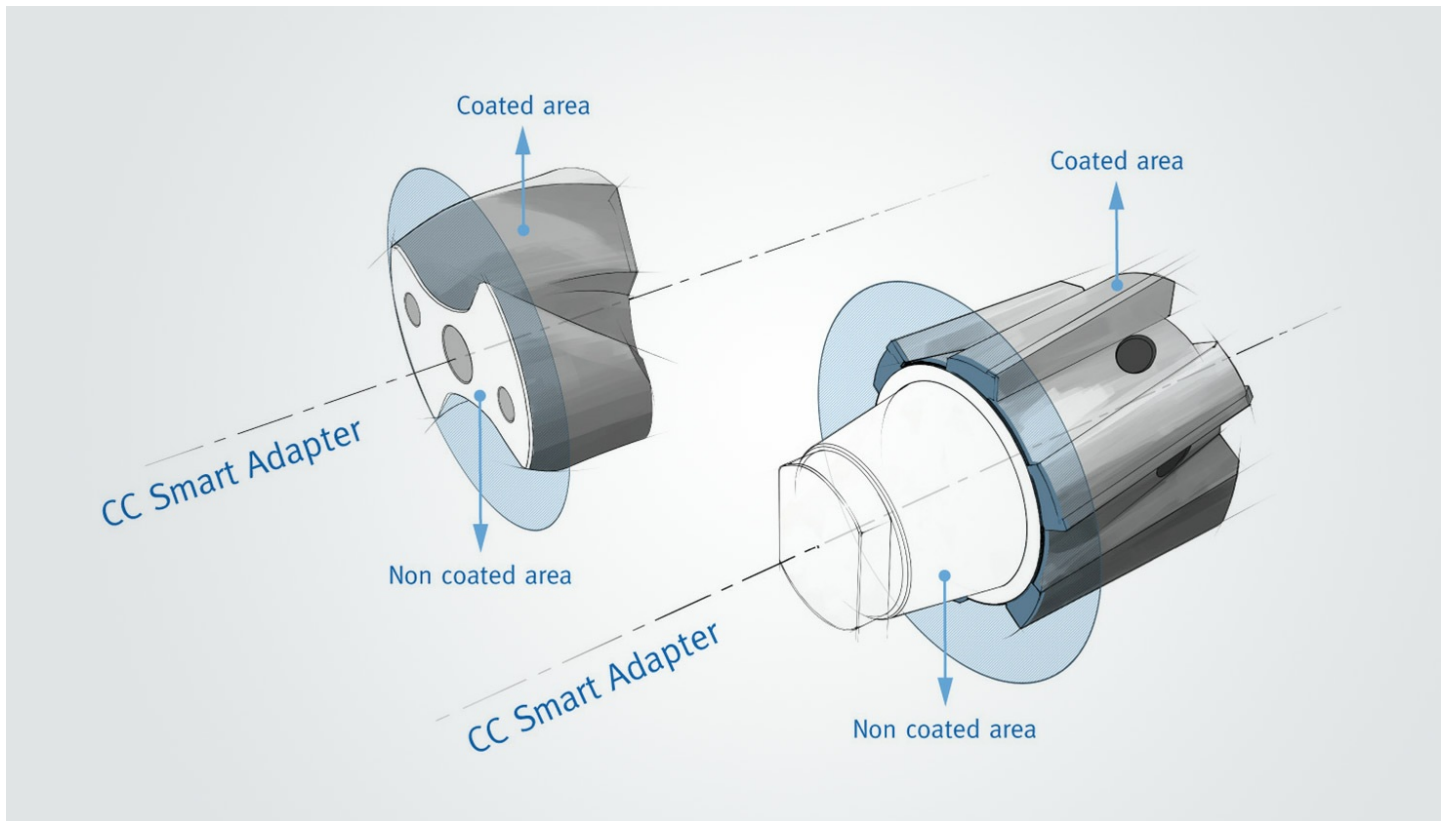

The smart batching solution guarantee maximum repeat accuracy for all types of interfaces.

## High-performance premium coatings for tools with replaceable heads

Replaceable head systems are an increasingly popular alternative to conventional shank tools in machining. They score with high repeat accuracy and short non-productive times, as the base frame can remain in the spindle and only the cutting head is replaced. Users can further increase productivity with the high-performance HiPIMS coating layers. CemeCon adapts all types of interfaces with a smart batching solution for maximum repeat accuracy.

The foresighted use of resources is important – all the more so, as carbide is increasingly becoming a scarce commodity. As a result, more and more tool manufacturers are relying on replaceable head systems to keep material usage as low as possible. “These replaceable heads must be able to withstand the same high loads in the machining process as their shank counterparts. For this, modern coating solutions based on our HiPIMS coating materials FerroCon®, InoxaCon® and AluCon® are the media of choice for increasing the performance of the tools. Due to their outstanding properties, cutting speeds can be increased and surface qualities improved, for example. This makes replaceable head systems even more economical,” says Manfred Weigand, Product Manager Round Tools at CemeCon.

However, coating the cutting heads is a challenge due to the large number of different adapter systems. CemeCon has a smart solution for this: “We use a special adaptation system that is both suitable for the

manufacturer's individual interfaces and universal enough for an efficient coating process. The adapter points on the replaceable heads, which must not be coated, are covered, as the system enables clearly delimited coating areas. Our solution guarantees a high level of process reliability, which ensures that our customers always receive their tools with the same coating specification and the consistent quality. This has been successful, as proven by many thousands of coated replaceable heads,” explains Manfred Weigand.

[FerroCon®](#)

[InoxaCon®](#)

[AluCon®](#)

[Job coating service](#)

[Coating development](#)

[Coating centre](#)

[Process reliability](#)

[Smart adapter](#)

[Replaceable head systems](#)